

AVAILABLE IN 0.3M, 0.6m, 0.9m, 1.2m, 1.5m, 1.8m, 2.1m, & 2.5m HEIGHTS

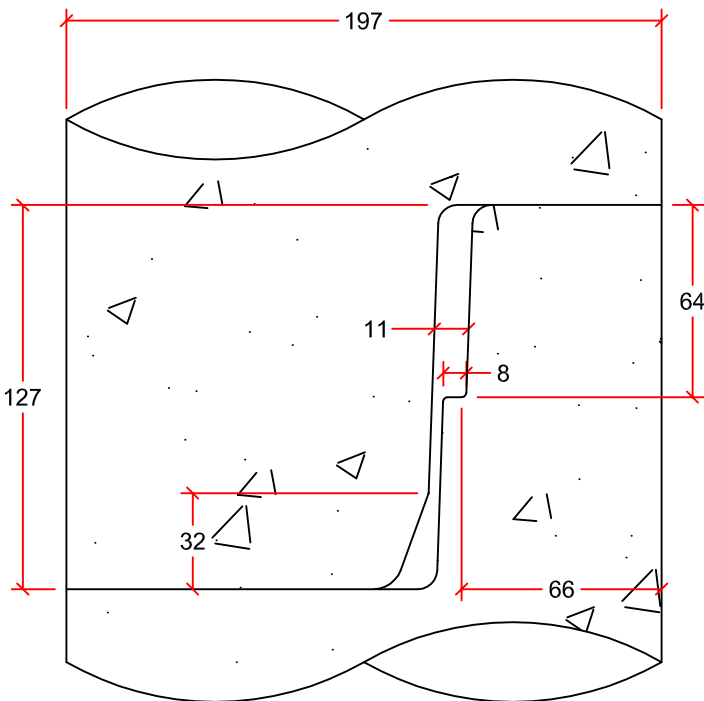

JOINT DETAIL

HEIGHT (H) (mm)	MASS (kg)
300	940
600	1880
900	2820
1200	3760
1500	4700
1800	5640
2100	6580
2500	7520

DRAWN BY:	AARON KLEMETS	1800mm MANHOLE RISER	
SCALE:	NTS		
DATE:	NOVEMBER 17, 2015	ALL DIMENSIONS IN mm TWO 8T LIFT PINS PROVIDED AS SHOWN	
DRAWING #:	1800 MH RISER		
REVISION #:	REV. 0		
CHECKED BY:	TYSON DYCK	9265 OAK ST. VANCOUVER B.C. PH: 604 269-6700 FAX: 604 261-6751	